

TFPM Series

Tuning Fork Crystal

Features

- 32.7680kHz Frequency Reference
- Tuning Fork Crystal Design
- Plastic Molded Surface Mount Package
- Compatible to Citizen CM200C/S and Epson MC-306
- Frequency Tolerance, ± 20 ppm Standard
- Parabolic Temperature Coefficient
- Tape and Reel Packaging, EIA-418



Part Dimensions:
8.0 × 3.8 × 2.5mm • 145.1782mg

RoHS Compliant in Accordance with EU Directive 2011/65/EU

- Lead-Free Termination Finish
- Exemption 7(a), Lead [Pb] in high melting temperature type solders

Applications

- Real Time Clock Reference
- FPGAs & Microcontrollers
- Wireless Communications
- Consumer Electronics
- Computer Peripherals
- IoT Applications
- Instrumentation
- Industrial Electronics

Description

CTS TFPM Series is ideal for supporting wide range of electronic designs requiring a Real Time Clock reference. This series will support general commercial and industrial applications.

Ordering Information

Model		Frequency Tolerance	Load Capacitance	Frequency Code [kHz]	Packaging
TF	PM	2	P	32K7680	R
↓		↓		↓	
Code	Package	Code	Capacitance	Code	
PM	8.0x3.8mm	P	12.5pF	R	
[Plastic Molded]		T	6pF	3k pcs./reel	
↓		↓		↓	
Code	@ +25°C	Code		Frequency	
2	± 20 ppm	Product Frequency Code ²			
1	± 10 ppm ¹				

Notes:

- 1] Check factory for availability.
- 2] Frequency is recorded with two leading digits before the 'K' and 4 significant digits after the 'K' [including zeros].

Not all performance combinations and frequencies may be available.
Contact your local CTS Representative or CTS Customer Service for availability.

This product is specified for use only in standard commercial applications. Supplier disclaims all express and implied warranties and liability in connection with any use of this product in any non-commercial applications or in any application that may expose the product to conditions that are outside of the tolerances provided in its specification.

Mechanical Specifications

Package Drawing

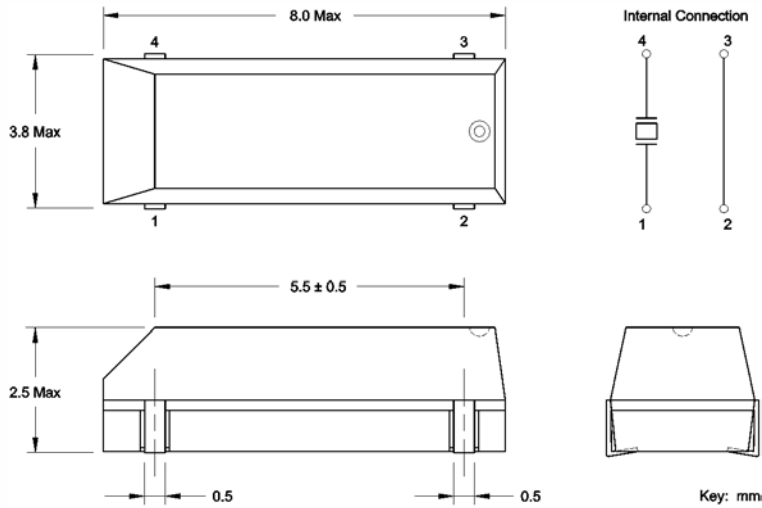

Marking Information

Refer to document 016-0071-0, TF Marking Guide, for marking formats by product family.

Recommended Pad Layout

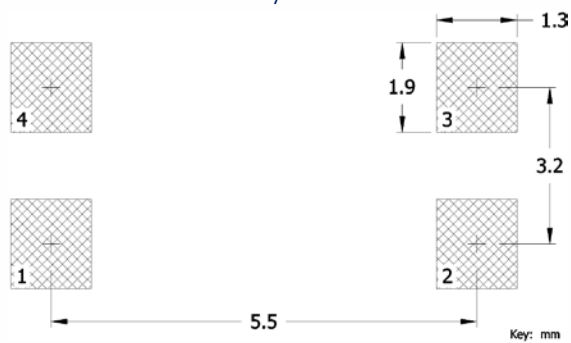

Notes

1. JEDEC termination code (e3). Barrier-plating is nickel [Ni] with tin [Sn] plate.
2. Reflow conditions per JEDEC J-STD-020; +260°C maximum, 10 seconds.
3. MSL = 1.