

PAD	CONNECTION
1	Crystal
2	Ground & lid
3	Crystal
4	Ground & lid

Features

- ▶ AEC-Q200 qualified for automotive apps
- ▶ Seam sealed for excellent long-term stability
- ▶ High reliability at low cost
- ▶ Metal lid can be grounded to minimise EMI
- ▶ Miniature for maximum space/weight saving

Example Applications

- ▶ Vehicle telematics
- ▶ Connected car
- ▶ Remote Keyless Entry (RKE)
- ▶ Audio - DAB / Bluetooth
- ▶ Camera

Specifications

Parameters	Product	Option Codes
	GRX-320	
Frequency range:	12.0 ~ 40.0MHz	■
Calibration tolerance:	±10ppm ±15ppm ±20ppm Other values	□ ■ □ □
Temperature stability:	±15ppm ±20ppm ±50ppm ±100ppm Other values	□ □ □ □ □
Operating temperature range:	-40 to +85°C -40 to +125°C Other values	□ □ □
Storage temperature range:	-40 to +125°C	■
Circuit condition:	8pF 10pF 12pF 16pF Other values	□ □ □ □ □
Oscillation mode:	Fundamental	■
Static capacitance (C ₀):	5pF max	■
Equivalent series resistance (max):	150Ω (12.0 ~ 15.99MHz) 80Ω (16.0 ~ 19.99MHz) 60Ω (20.0 ~ 29.99MHz) 50Ω (30.0 ~ 34.99MHz) 40Ω (35.0 ~ 40.0MHz)	■ ■ ■ ■ ■
Ageing:	±3ppm max first year	■
Test drive level:	10μW typ, 100μW max	■
Soldering condition:	260°C, 10 sec x2 max	■

■ Standard. □ Optional - Please specify required code(s) when ordering

Ordering Information

Product name + option codes + frequency
 eg: **GRX-320/PP4DF 13.560MHz** 15/15/-40+85/16-F
GRX-320/25ABF 27.0MHz 20/50/-40+125/12-F
 Option code X (eg GRX-320/X) denotes a custom specification.

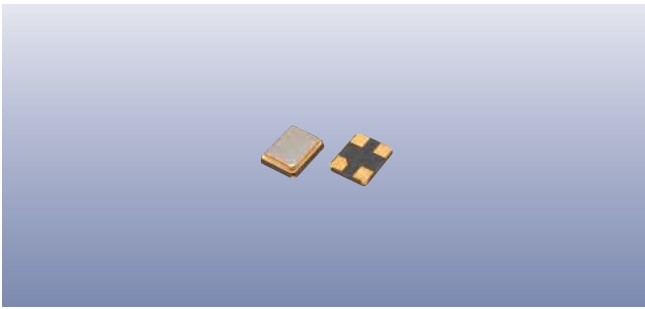

Construction

- Ceramic body with gold-plated pads
- Metal lid, seam sealed

Composition



This product is lead-free, and is fully compliant with the RoHS directive 2011/65/EU



Packaging & Handling

Production quantities supplied on T&R, 3k pcs per reel.
Small quantities may be supplied on tape (no reel), or in bulk.

Marking

FREQUENCY
S DC

Marking type: Laser
DC = Date code in YM, as shown below
Example: "EJ" = Sep 2015

	A	B	C	D	E	F	G	H	J	K	L	M
Y	1	2	3	4	5	6	7	8	9	0		
M	Jan	Feb	Mar	Apr	May	Jun	Jul	Aug	Sep	Oct	Nov	Dec

Tape & Reel Specification

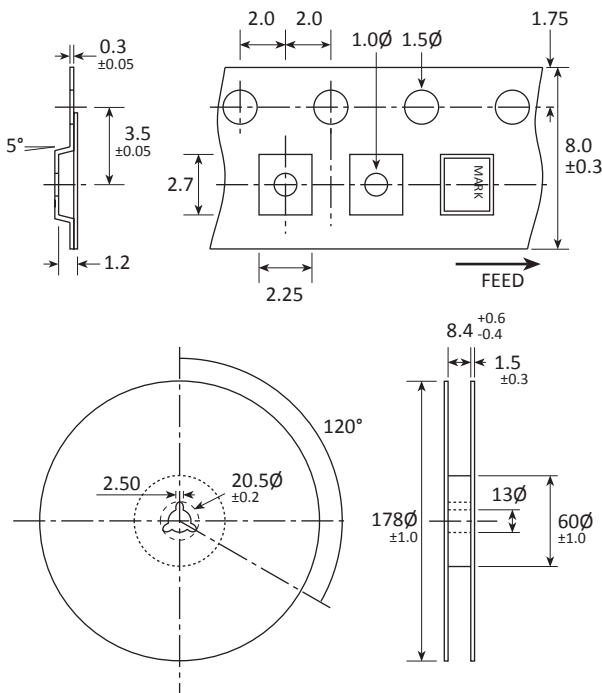

Not to scale. Dimensional tolerances ±0.1mm unless otherwise stated.

Soldering Profile

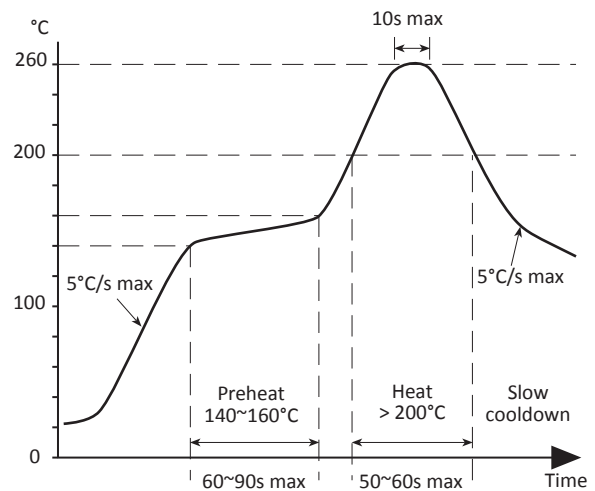

Maximum solder resistance: 260°C x 10 secs x 2.