

PAD	CONNECTION
1	Enable/Disable
2	Ground
3	Output
4	Supply

Features

- ▶ Excellent temperature stability
- ▶ Low current consumption
- ▶ AT-cut resonator + dividing circuit
- ▶ Miniature ceramic package with metal lid
- ▶ Competitive pricing

Specifications

Parameters	Product	Option Codes
	GAO-3201	
Frequency:	32.768kHz	■
Frequency stability:	±25ppm	■ A
Operating temperature range:	-40 to +85°C	■ I
Storage temperature range:	-55 to +125°C	■
Supply voltage (V _{DD}):	Operable from +1.8 ~ +5.0V	■
Supply current (@ 15pF):	0.108mA typ, 0.200mA max (1.8V) 0.117mA typ, 0.200mA max (3.3V)	■
Driving ability:	15pF CMOS	■
Logic levels:	'0' level = 10%V _{DD} max '1' level = 90%V _{DD} min	■
Waveform symmetry:	45:55 @ 50%V _{DD}	■
Rise / fall time:	13ns typ 100ns max, 10 ~ 90%V _{DD}	■
Startup time:	10ms max	■
Stand-by current:	2µA typ, 10µA max	■
Ageing:	±5ppm/yr max @ 25°C	■

■ Standard. □ Optional - Please specify required code(s) when ordering

Ordering Information

Product name + option codes
eg: **GAO-3201/AI** 1.8~5.0V, ±25ppm, -40+85°C

Enable / Disable Function

Input (pad 1)	Output (pad 3)
Open	Enabled
'1' level (V _{IH} = 70% V _{DD} min)	Enabled
'0' level (V _{IL} = 30% V _{DD} max)	High Impedance

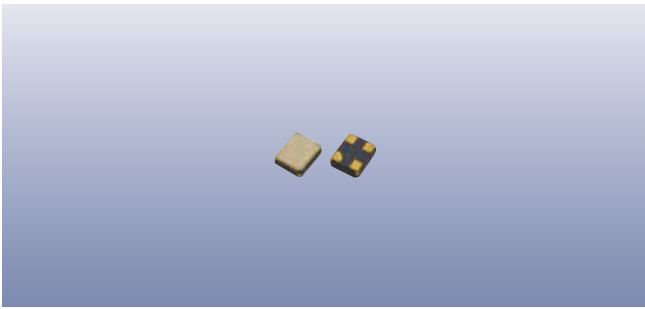

Construction

- ▮ Ceramic body with gold-plated pads
- ▮ Metal lid, seam sealed

Composition



This product is lead-free, and is fully compliant with the RoHS 2 directive 2011/65/EU



Packaging & Handling

Production quantities supplied on T&R, 1k or 3k pcs per reel. Small quantities may be supplied on tape (no reel), or in bulk.



◆ Static sensitive product. Observe proper handling precautions

Marking

FREQUENCY
S DC

Marking type: Laser
DC = Date code in YM, where Y is numeric and M is a letter, eg "4F" = June 2014

	A	B	C	D	E	F	G	H	J	K	L	M
M	Jan	Feb	Mar	Apr	May	Jun	Jul	Aug	Sep	Oct	Nov	Dec

Tape & Reel Specification

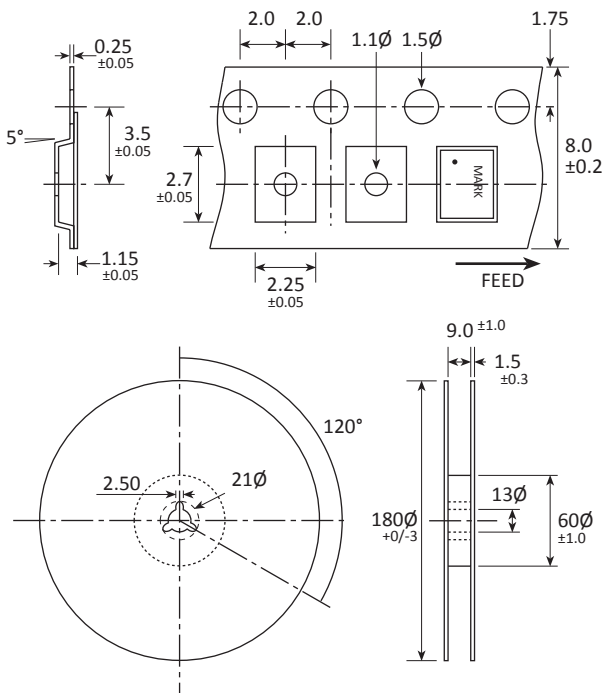

Not to scale. Dimensions in mm. Tolerances ±0.1mm unless otherwise stated.

Soldering Profile

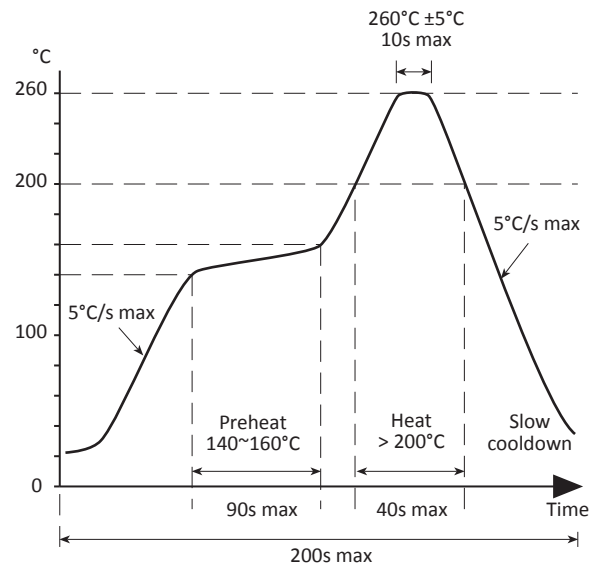

Solder resistance: 260°C x 10 secs x 2.