

PAD	CONNECTION
1	Ground or Freq adjustment
2	Ground
3	Output
4	Supply

Features

- ▶ Supply voltages from 2.4V ~ 5.5V
- ▶ Low power consumption
- ▶ Miniature SM package
- ▶ Excellent frequency stability

Specifications

GTXO-83T: TCXO, no frequency adjustment

GTXO-83V: TCXO with VC frequency adjustment

Parameters	Variant		Option Codes
	T	V	
Frequency range:	6.0 ~ 45.0MHz	■	■
Frequency stability:	±3.0ppm	□	□
	±2.5ppm	■	■
	±2.0ppm	□	□
	±1.5ppm	□	□
Temperature range:	0 to +50°C	□	□
	-10 to +60°C	□	□
	-20 to +70°C	□	□
	-30 to +75°C	■	■
	-40 to +85°C	□	□
Storage temperature range:	-40 to +85°C	■	■
Supply voltage stability:	±0.2ppm, V _{DD} ±5%	■	■
Load stability:	±0.2ppm, Z _L ±10%	■	■
Ageing:	±1.0ppm max first year	■	■
Supply voltage (V _{DD}):	+2.4V ~ +5.5V (see note)	■	■
Supply current (max):	1.5mA (6.0 ~ 20.0MHz)	■	■
	2.0mA (20.0 ~ 32.0MHz)	■	■
	2.5mA (32.0 ~ 45.0MHz)	■	■
Output waveform:	Clipped sine, 0.8V p-p, +DC offset	■	■
Test load (Z _L):	10kΩ // 10pF	■	■
Start up time:	3ms max	■	■
Frequency adjustment:	None	■	■
	±8ppm min, +1.5 ±1.0V		
Phase noise (typ @ 20.0MHz):	-54dBc/Hz @ 1Hz	■	■
	-86dBc/Hz @ 10Hz	■	■
	-135dBc/Hz @ 1kHz	■	■
	-151dBc/Hz @ 100kHz	■	■
Frequency tolerance @ 25°C:	±2.0ppm max, 60mins after reflow	■	■

■ Standard. □ Optional - Please specify required code(s) when ordering

Ordering Information

Product name + variant + option codes + frequency
Option codes must be included to properly specify a model.

eg: **GTXO-83V/JS 13.00MHz** ±2.5ppm -30+75°C, TCXO with VC

GTXO-83T/HN 14.40MHz ±2.0ppm -20+70°C, TCXO no VC

Option code X (eg GTXO-83V/X) denotes a custom spec.

♦ Will operate within specification on any supply voltage from +2.4V to +5.5V.

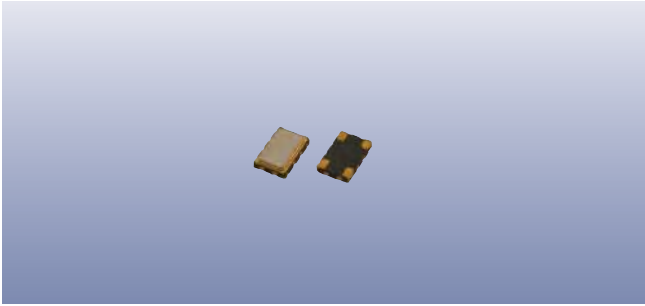

Packaging & Handling

Production quantities supplied on T & R, 1k pcs per reel.
Small quantities may be supplied on tape (no reel), or in bulk.

 Static sensitive product. Observe proper handling precautions

Marking

S83 DC **DC**
FREQUENCY

Marking type: Laser
DC = Date code in YM, eg "CE" = May 2013

	A	B	C	D	E	F	G	H	J	K	L	M
Y	1	2	3	4	5	6	7	8	9	0		
M	Jan	Feb	Mar	Apr	May	Jun	Jul	Aug	Sep	Oct	Nov	Dec

Tape & Reel Specification

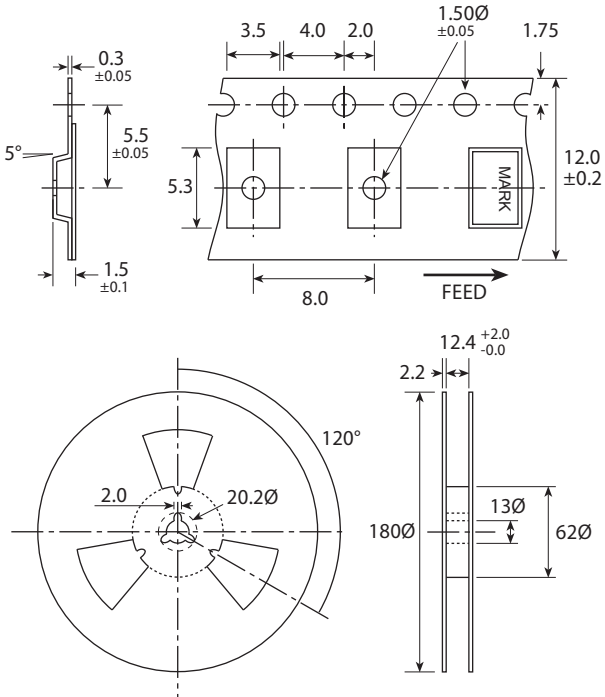



Not to scale. Dimensions in mm. Tolerances ±0.1mm unless otherwise stated

Construction

- Ceramic body with gold-plated pads
- Metal lid, seam sealed

Composition

 This product is lead-free, and is fully compliant with the RoHS directive 2011/65/EU 

Soldering Profile

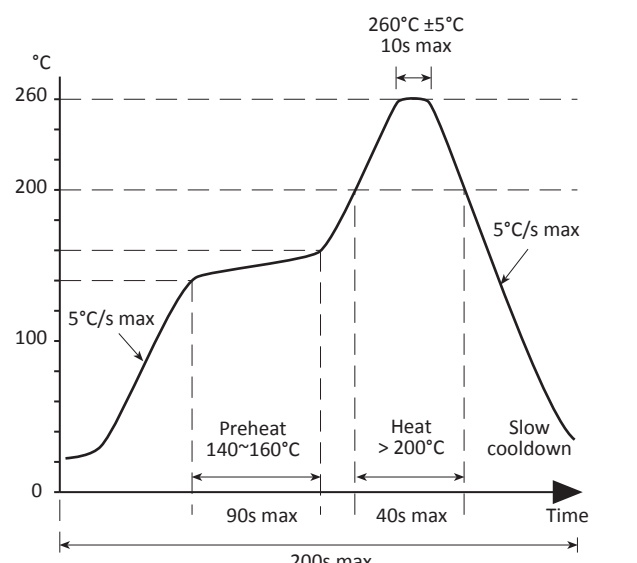

Solder resistance: 260°C x 10 secs x 2.