



actual size

SMD Quartz Crystal · SMU5

4 Pad Version · 13.1 x 5.0 mm

- MG3A replacement type
- reflow soldering temperature: 260 °C max.
- package height 5 mm



General Data

type		SMU5
frequency range	fund. AT-cut	3.27680 ~ 33.0 MHz (> 33.0 MHz, ask if available)
	3rd OT AT-cut	ask for availability
	fund. BT-cut	ask for availability
frequency tolerance at 25 °C		± 20 ppm ~ ± 50 ppm / ± 50 ppm if ≤ 3.57 MHz
load capacitance C_L		12 pF ~ 32 pF or series / 30 pF standard
shunt capacitance C_0		< 5 pF
storage temperature		-40 °C ~ +125 °C
drive level max.		500 µW (100 µW recommended)
aging		< ± 5 ppm first year

ESR (series resistance Rs)

frequency in MHz	vibration mode	ESR max. in Ω	ESR typ. in Ω
3.276 ~ 3.499	fund. AT	200	100
3.500 ~ 3.999	fund. AT	120	80
4.000 ~ 5.999	fund. AT	80	60
6.000 ~ 6.999	fund. AT	70	35
7.000 ~ 8.999	fund. AT	50	25
9.000 ~ 13.999	fund. AT	35	15
14.000 ~ 19.999	fund. AT	30	10
20.000 ~ 40.000	fund. AT	20	10
ask	3rd OT AT	(100)	(60)
ask	fund. BT	(50)	(20)

numbers in brackets () only for reference

Frequency Stability vs. Temperature

		± 20 ppm	± 30 ppm	± 50 ppm	± 100 ppm	± 150 ppm	+10/-100 ppm
-20 °C ~ +70 °C	STD	D	●	○			○ BT-cut
-40 °C ~ +85 °C	T1		○	● (*)	○		
-40 °C ~ +105 °C	T2			○	○		
-40 °C ~ +125 °C	T3				D	○	

● standard ○ available D ask, if available (*) if ≤ 3.57 MHz, not better than ± 100 ppm at temp. range T1

Marking

frequency with load capacitance code
company code / date code / internal code

	Jan.	Febr.	Mar.	Apr.	May	June	July	Aug.	Sept.	Okt.	Nov.	Dec.
2012	n	p	q	r	s	t	u	v	w	x	y	z
2013	A	B	C	D	E	F	G	H	J	K	L	M
2014	N	P	Q	R	S	T	U	V	W	X	Y	Z
2015	a	b	c	d	e	f	g	h	i	k	l	m

Dimensions

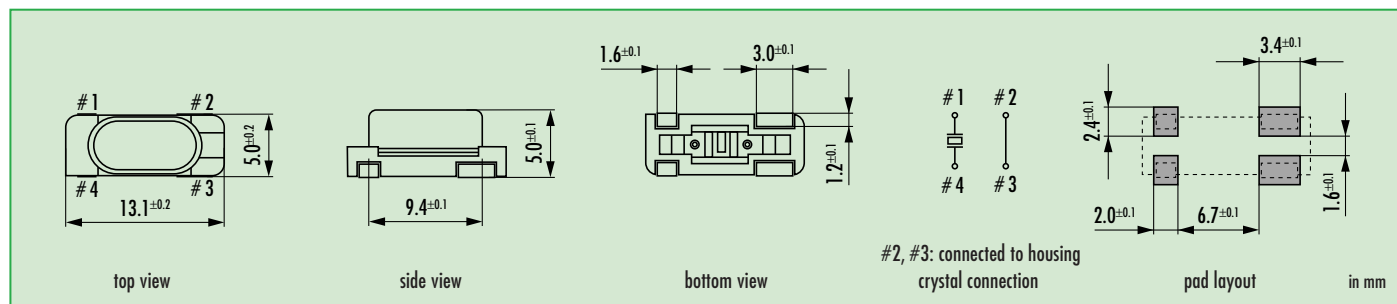

Order Information

Q	frequency	type	load capacitance	stability at 25 °C	stability vs. temp. range	option
Quartz	3.27680 ~ 33.0 MHz	SMU5	30 pF standard 12 pF ~ 32 pF S for series	30 = ± 30 ppm std 20 = ± 20 ppm 50 = ± 50 ppm	see table	blank = -20 °C ~ +70 °C T1 = -40 °C ~ +85 °C T2 = -40 °C ~ +105 °C T3 = -40 °C ~ +125 °C FU = for fundamental frequencies ≥ 20 MHz 30T = 3rd overtone (if available) BT = fundamental BT-cut (if available)

Example: Q 30.0-SMU5-30-30/50-T1-FU-LF (Suffix LF = RoHS compliant / Pb free pins or pads)

