

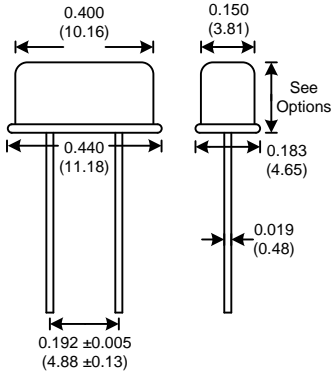

CYSxx Model

Low Profile HC49S Leaded Crystal



Dimensions inches (mm)
All dimensions are maximum unless otherwise specified

Resistance at series resonance	
Freq. (MHz)	Max ESR
3.579545 - 4.0	150
4.1 - 4.9	120
5.0 - 5.9	100
6.0 - 11.9	90
12.0 - 14.9	70
15.0 - 30.0	50
30.1 - 86.0	100

Table 1



Part number	Freq. (MHz)	CL	Max ESR
CY3DMS	3.579545	18pF	150
CY3JS	3.686400	series	150
CY3JMS	3.686400	18pF	150
CY3JNS	3.686400	20pF	150
CY3AS	4.000	series	150
CY3APS	4.000	20pF	150
CY4ES	4.194304	12pF	120
CY4DS	4.915200	series	120
CY7AS	5.000	series	100
CY7APS	5.000	20pF	100
CY5BS	5.0688	series	100
CY6BS	6.000	series	90
CY6BPS	6.000	20pF	90
CY8GS	8.000	series	90
CY8GPS	8.000	20pF	90
CY9BS	9.830400	series	90
CY12AS	10.000	series	90
CY11BS	11.059200	series	90
CY11BPS	11.059200	20pF	90
CY12BS	12.000	series	70
CY12BPS	12.000	20pF	70
CY14AS	14.318180	series	70
CY14ACS	14.318180	18pF	70
CY14APS	14.318180	20pF	70
CY14BS	14.745600	series	70
CY14BPS	14.745600	20pF	70
CY15AS	15.000	series	50
CY16BS	16.000	series	50
CY16BPS	16.000	20pF	50
CY19AS	18.000	series	50
CY19BS	18.432	series	50
CY19BPS	18.432	20pF	50
CY20AS	19.660800	series	50
CY20APS	19.660800	20pF	50
CY22AS	20.000	series	50
CY22APS	20.000	20pF	50
CY24AS	24.000	series	50
CY24APS	24.000	20pF	50
CY25AS	25.000	series	50

Frequency Range: 3.579545 MHz to 40 MHz (fund)
27 MHz to 86 MHz (3rd O/T)

Calibration Tolerance: ±50ppm (Standard p/n)
(Option) ±10ppm to ±100ppm

Frequency Stability: ±100ppm (Standard p/n)
(Option) ±15ppm to ±100ppm

Operating Temp. range: 0 to 70°C (Standard p/n)
(Option) -20 to 70°C
(Option) -40°C to 85°C

Storage Temp. range: -45°C to 90°C

Shunt Capacitance: 7.0pF Max

Drive level: 100uW Typical

ESR: See table 1

Aging: <3ppm 1st year Max

Insulation Resistance: 500 Megaohms Min at 100Vdc

****Custom Designs Available****

Build Your Own P/N

CYS X X X X X - Freq

Frequency Tolerance at 25°C

- 1 ±10 ppm
- 2 ±15 ppm
- 3 ±20 ppm
- 4 ±25 ppm
- 5 ±30 ppm
- 6 ±50 ppm
- 7 ±100 ppm

Frequency Stability over Temp Range

B ±15 ppm (0 to 70°C)	J ±30ppm (-20 to 70°C)
C ±20 ppm (0 to 70°C)	K ±50 ppm (-20 to 70°C)
D ±25 ppm (0 to 70°C)	L ±100 ppm (-20 to 70°C)
E ±30 ppm (0 to 70°C)	M ±20 ppm (-40 to 85°C)
F ±50 ppm (0 to 70°C)	N ±25 ppm (-40 to 85°C)
G ±100 ppm (0 to 70°C)	O ±30 ppm (-40 to 85°C)
H ±15 ppm (-20 to 70°C)	P ±50 ppm (-40 to 85°C)
I ±20 ppm (-20 to 70°C)	Q ±100 ppm (-40 to 85°C)

Load Capacitance

- 1 Series
- 2 14 pF
- 3 16 pF
- 4 18 pF
- 5 20 pF
- 6 22 pF
- 7 25 pF
- 8 32 pF

Options

Can Height (Max)	
A	2.5mm
AS	2.5mm w/ spacer
B	4.0mm
BS	4.0mm w/ spacer
C	5.0mm
CS	5.0mm w/ spacer

Mode

- 1 Fundamental 3.579545-40 MHz
- 3 3rd Overtone 27-86 MHz

Example:

CYS4F51CS-20.000 = ±25ppm at 25°C, ±50ppm 0 to 70°C, 20pF Load Cap, Fundamental, 5.0mm with Spacer, 20.000 MHz

Specifications subject to change without notice.

TD-021005 Rev. F