

QC16 Series

1.2x1.6 4-Pad SMD Quartz Crystal Unit



Features

- 1.2 x 1.6 x 0.4mm ultra miniature package
- Seam sealed ceramic package with metal lid assures high precision and reliability

Applications

- High density applications
- Modem, communication and test equipment
- PMCIA, wireless applications
- Automotive applications



General Specifications	
Frequency Range	24.000 to 40.000MHz (Fundamental)
Frequency Tolerance at 25°C	±15 to ±30ppm (±30ppm standard)
Frequency Stability over Temperature Range	See Stability vs. Temperature Table
Storage Temperature	-55 to +125°C
Aging per Year	±3ppm max.
Load Capacitance C_L	7 to 32pF and Series Resonance
Shunt Capacitance C_0	3.0pF
Equivalent Series Resistance (ESR)	See ESR Table
Drive Level	100µW max.
Insulation Resistance (MΩ)	500 at 100Vdc ±15Vdc

Equivalent Series Resistance (ESR)		
Frequency Range - MHz	Ω max.	Mode of Operation
24.000 to 31.999	120	Fundamental
32.000 to 38.399	100	
38.400 to 40.000	80	

Frequency Stability vs. Temperature					
Operating Temperature	±10ppm	±20ppm	±30ppm	±50ppm	±100ppm
-20 to +70°C	○	○	○	○	○
-40 to +85°C	○*	○	●	○	○
-40 to +105°C	-	-	-	○	○
-40 to +125°C	-	-	-	-	○

*Operating Temperature -30 to +80°C ● standard ○ available

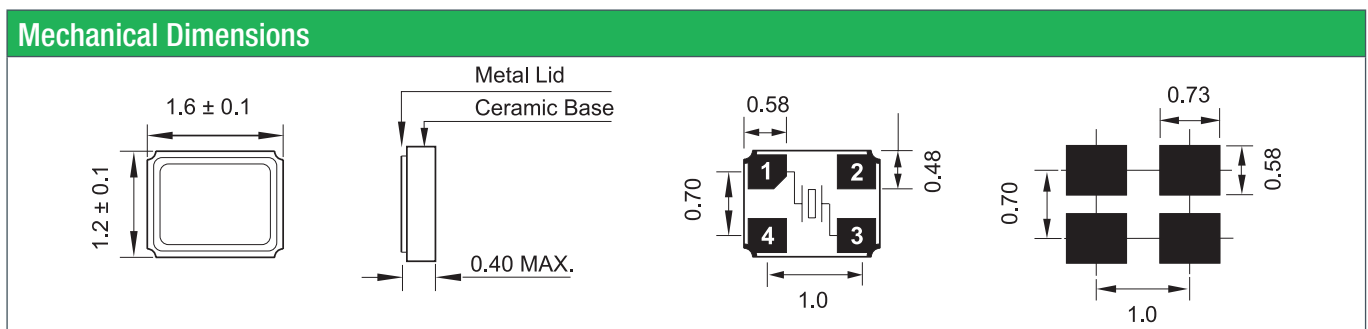

Part Numbering Guide

Qantek Code	Package	Nominal Frequency (in MHz)	Vibration Mode	Load Capacitance	Operating Temperature Range	Frequency Tolerance	Frequency Stability	Automotive Indicator	Packaging
Q = Qantek	C16 = 1.2x1.6 4-Pad SMD	7 digits including the decimal point (f.i.e. 12.0000)	F = AT-Fund	S = Series 08 = 8pF 12 = 12pF 18 = 18pF 20 = 20pF etc.	A = -20 to +70°C B = -40 to +85°C C = -40 to +105°C D = -40 to +125°C	1 = ±15ppm 2 = ±20ppm 3 = ±25ppm 4 = ±30ppm 5 = ±50ppm	1 = ±15ppm 2 = ±20ppm 3 = ±25ppm 4 = ±30ppm 5 = ±50ppm	not available	M = 250pcs Tape&Reel R = 1000pcs Tape&Reel R3 = 3000pcs Tape&Reel

Example: QC1624.0000F12B45R bold letters = recommended standard specification



QC16 Series

1.2x1.6 4-Pad SMD Quartz Crystal Unit

Tape and Reel Dimensions

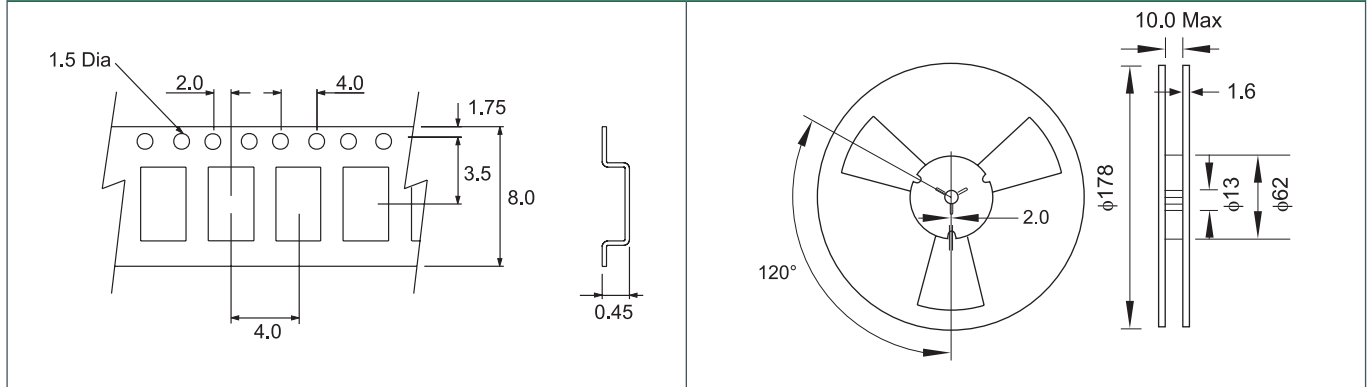

Marking Code Guide

Contains frequency, Qantek manufacturing code, production code (month and year) and load capacitance.

Year/Month Codes													Load Capacitance Code in pF			
	Jan	Feb	Mar	Apr	May	Jun	Jul	Aug	Sep	Oct	Nov	Dec	pF	PN Code	pF	PN Code
2011 / 2015	A	B	C	D	E	F	G	H	J	K	L	M	12	A	20	F
2012 / 2016	N	P	Q	R	S	T	U	V	W	X	Y	Z	18	B	22	G
2013 / 2017	a	b	c	d	e	f	g	h	j	k	l	m	8	C	30	H
2014 / 2018	n	p	q	r	s	t	u	v	w	x	y	z	10	D	32	I
													16	E	S	S

Example: First Line: 240 (Frequency) Second Line: QAA (Qantek - January 2015 - 12 pF)

Solder Reflow Profile

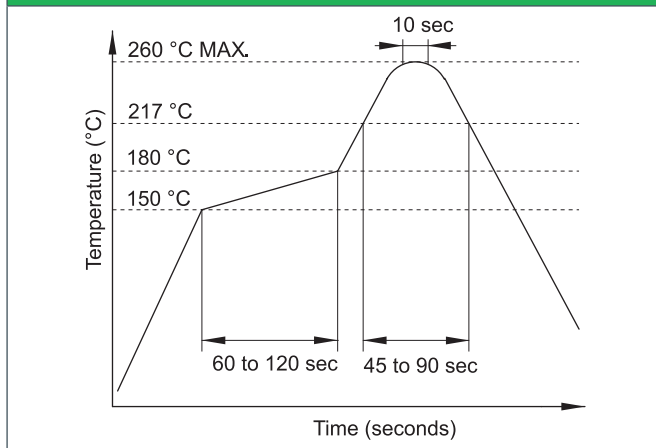

Environmental Specifications

Mechanical Shock	MIL-STD-202, Method 213, C
Vibration	MIL-STD-202, Method 201 & 204
Thermal Cycle	MIL-STD, Method 1010, B
Gross Leak	MIL-STD-202, Method 112
Fine Leak	MIL-STD-202, Method 112

All specifications are subject to change without notice.

