



## Quartz Crystal

SMD-version

model	KX – 12B
frequency range	8,0 ~ 50,0 MHz
mode	fundamental, 3 <sup>rd</sup> overtone upon request
operating temperature	standard -20° ~ + 70°C available -40° ~ + 85°C (=KX-12BT) available -40° ~ +105°C (=KX-12BE)
frequency tolerance at +25°C	± 30 ppm
temperature tolerance -20° ~ + 70°C -40° ~ + 85°C -40° ~ +105°C	standard ± 50 ppm, available ±10 ~ ±30 ppm standard ±100 ppm, available ±30 ~ ±50 ppm standard ±120 ppm, available ±50 ~ ±80 ppm
load capacitance $C_L$	standard 16 pF available 12 ~ 20 pF
series resonance R1 max.	8,0 ~ 9,79 MHz 150 Ohm 9,8 ~ 11,99 MHz 80 Ohm 12,0 ~ 50,0 MHz 40 Ohm
aging at +25°C (first year) max.	± 2 ppm
shunt capacitance $C_0$ max.	7,0 pF
drive level max.	0,05 mW
contents of reel	1000 pcs
part no.	12.xxxxx

### Dimensions (mm):

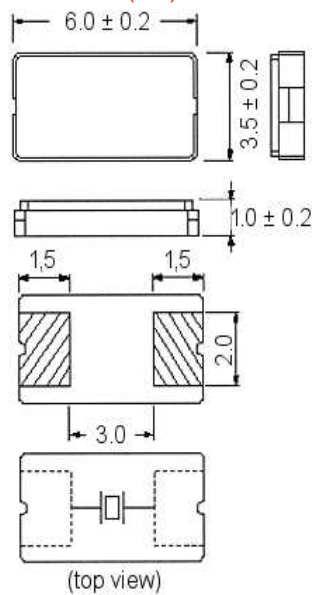

### Suggested soldering pad:

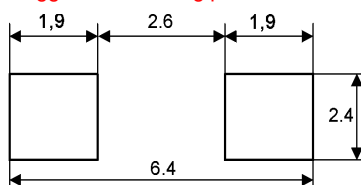

### Reflow soldering condition:

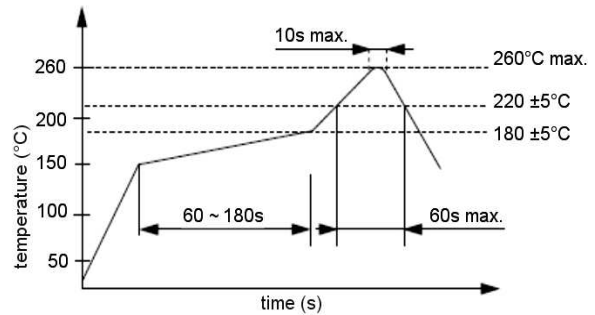

### Tape specification:

