

# SMX-4S

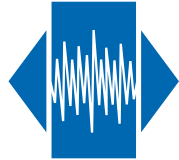

## Miniature SMD Crystal

### Features

- Applications: telecommunications, automotive, medical
- Wide frequency range: 12 to 50 MHz
- High shock and vibrational resistivity
- Reflow soldering @ 260 °C

Parameter	Specification	
Frequency range	12 ~ 50 MHz	fundamental
Mode of oscillation	AT-cut	
Standard frequencies	12.0, 13.00, 13.5344, 13.5825, 16.00, 18.080, 20.0, 24.0 24.576, 27.134375, 32.0 & 36.864 MHz	
Frequency tolerance	±10 ~ ±50 ppm	@ +25 °C
Frequency stability	±10 ~ ±50 ppm	vs. operating temperature range
Aging	±1 ppm	1 <sup>st</sup> year
Load capacitance	series or parallel resonance (CL = 8 ~ 32 pF)	
Equivalent series resistance (ESR)	< 20 Ω	@ 16 MHz
	< 15 Ω	@ 36 MHz
Drive level	10 ~ 100 μW	
Operating temperature range	-20 ~ +70 °C	commercial application
	-40 ~ +85 °C	industrial application
	-40 ~ +125 °C	automotive & avionic application
Storage temperature range	-55 ~ +125 °C	
Packaging unit	tape & reel	1'000 or 2'000 pieces
Customer specifications on request		

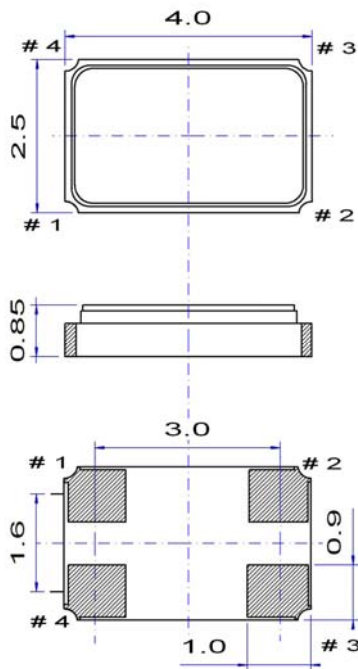

### Pin function

- # 1 crystal connection
- # 2 GND
- # 3 crystal connection
- # 4 GND

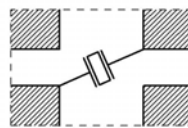

### Example for soldering pattern

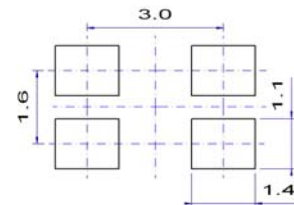

**Do not design any conductive path between the pattern**

### Example for IR reflow soldering temperature

