

- **FEATURES**
  - SUITABLE FOR TIME OF DAY CLOCKS
  - SMALL AND COMPACT PACKAGE
  - IDEAL FOR PICK AND PLACE ASSEMBLY

### SERIES RSM200S LEAD FREE



- **SPECIFICATIONS**

SERIES	RSM200S
NOMINAL FREQUENCY	32.768 KHz
FREQUENCY TOLERANCE AT 25°C	±20 PPM
TURNOVER TEMPERATURE	+25°C ±5°C
PARABOLIC CURVATURE CONSTANT	(-0.034 ±0.006) PPM/D C <sup>2</sup>
OPERATING TEMPERATURE	-40°C TO +85°C
STORAGE TEMPERATURE	-55°C TO +125°C
AGING (FIRST YEAR)	±3 PPM MAXIMUM
EQUIVALENT SERIES RESISTANCE (ESR)	50K OHMS MAXIMUM
LOAD CAPACITANCE	12.5 pF
SHUNT CAPACITANCE	1.35 pF TYPICAL
MOTIONAL CAPACITANCE	0.003 pF TYPICAL
CAPACITANCE RATIO	450 TYPICAL
DRIVE LEVEL	1 μW MAXIMUM
INSULATION RESISTANCE	500M OHM MINIMUM
SHOCK RESISTANCE	±5 PPM MAXIMUM 75cm DROP TEST ONTO A HARD SURFACE OR 3000g x 0.3ms x 1/2 SINEWAVE IN 3 AXES
REFLOW CONDITIONS	240°C FOR 10 SECONDS MAXIMUM (SEE PROFILE)



- **OUTLINE DRAWINGS**

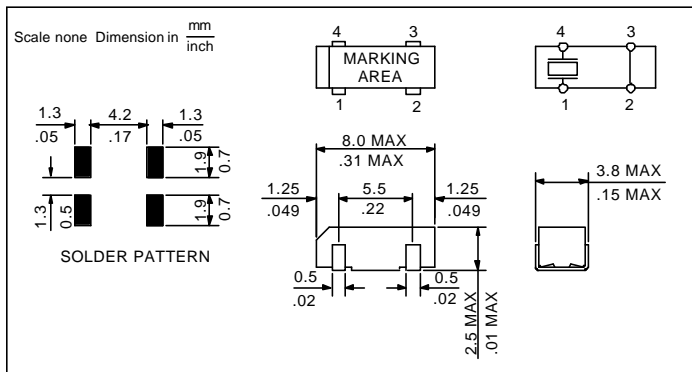

- **FREQUENCY VS. TEMPERATURE CURVE**

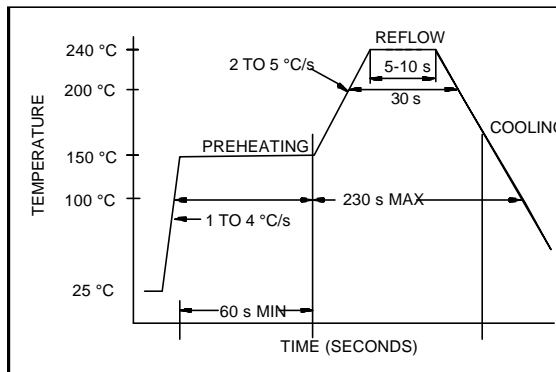

- **CARRIER TAPE DIMENSIONS**

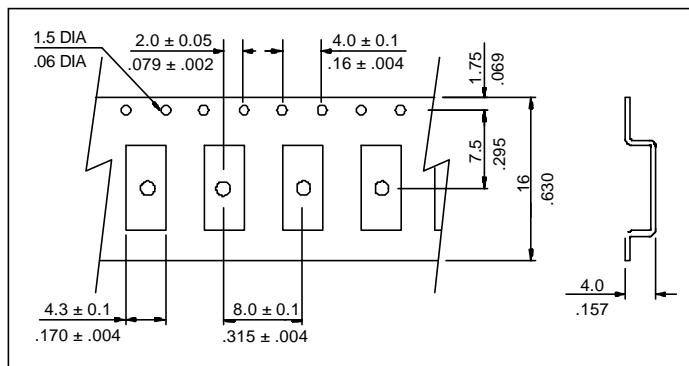

- **REFLOW SOLDERING PROFILE**

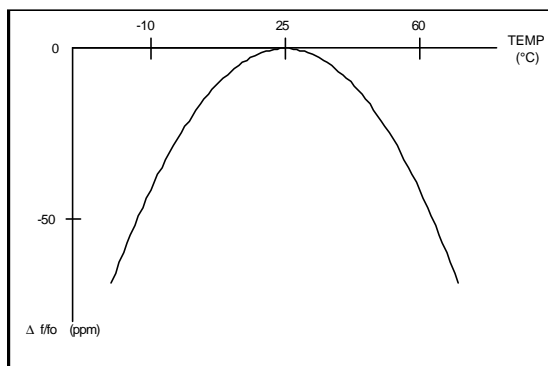

- **PACKAGING**

330 mm REEL DIAMETER, 16mm TAPE WIDTH, 8mm PITCH  
 QUANTITY: 3000 PIECES PER REEL

- **PART NUMBERING**

EXAMPLE: RSM-200S-32.768-12.5-TR